

GARDNER

LW
MARINE DIESEL ENGINES

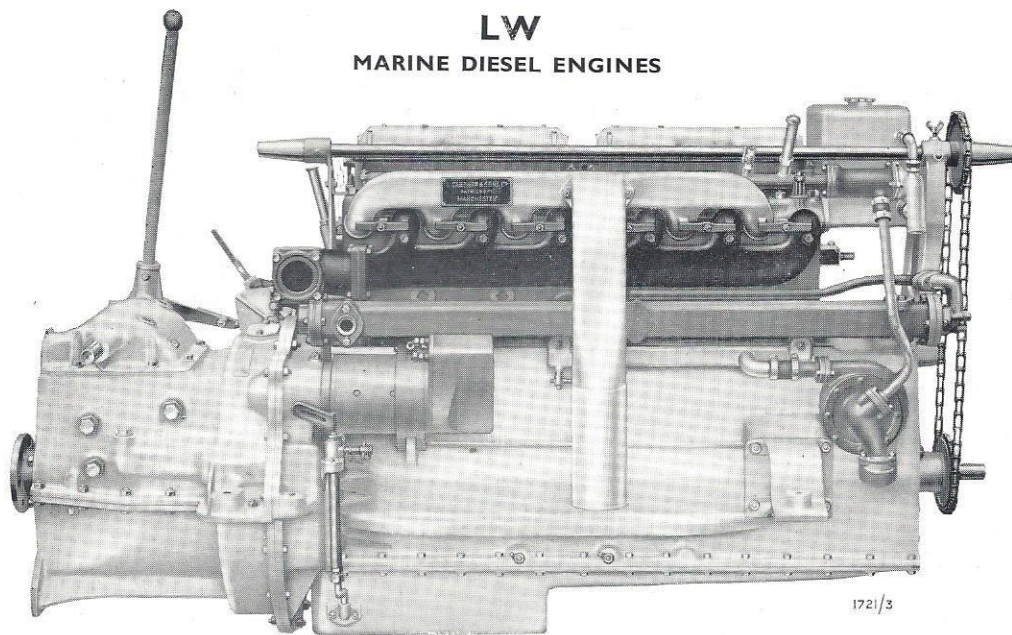

1721/3

Light alloy construction 6LW Engine and Reverse Gear Unit arranged for direct drive to propeller shafting.

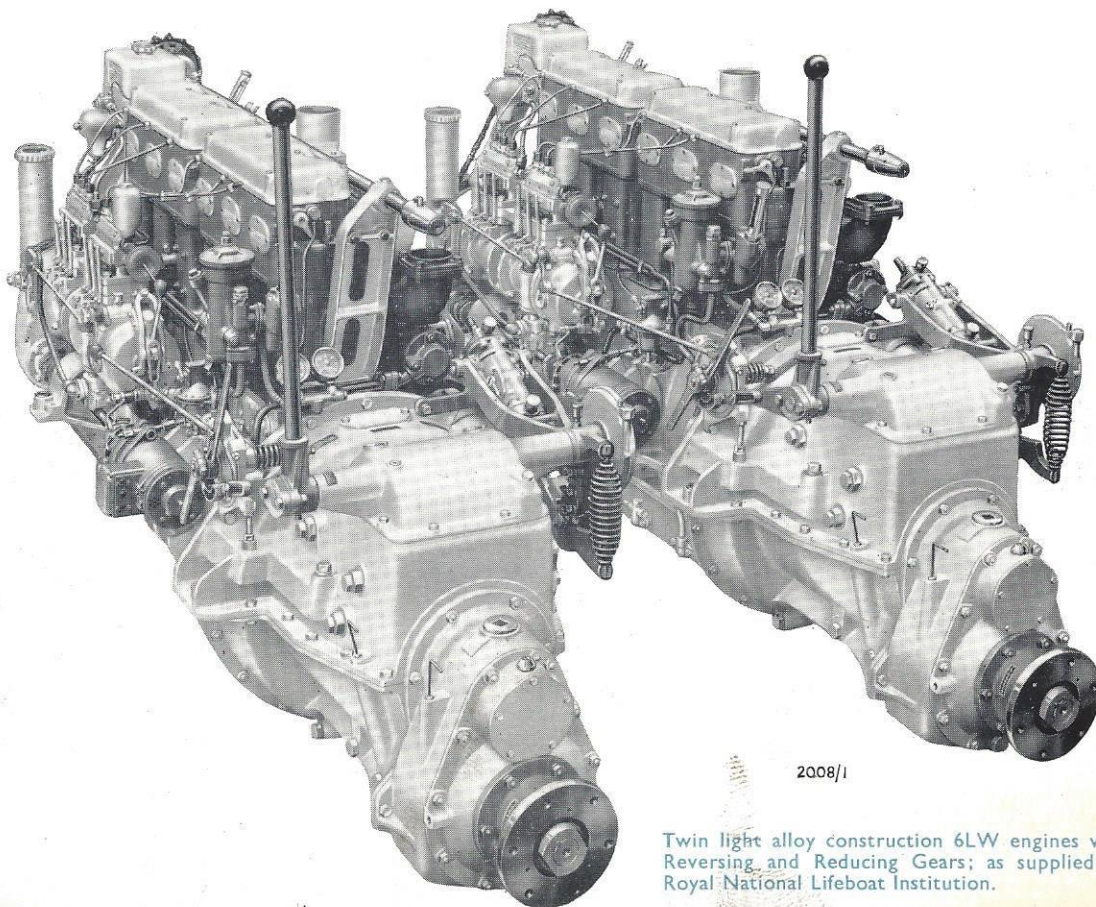

2008/1

Twin light alloy construction 6LW engines with 2:1 Reversing and Reducing Gears; as supplied to the Royal National Lifeboat Institution.

GARDNER

LW
MARINE DIESEL ENGINES

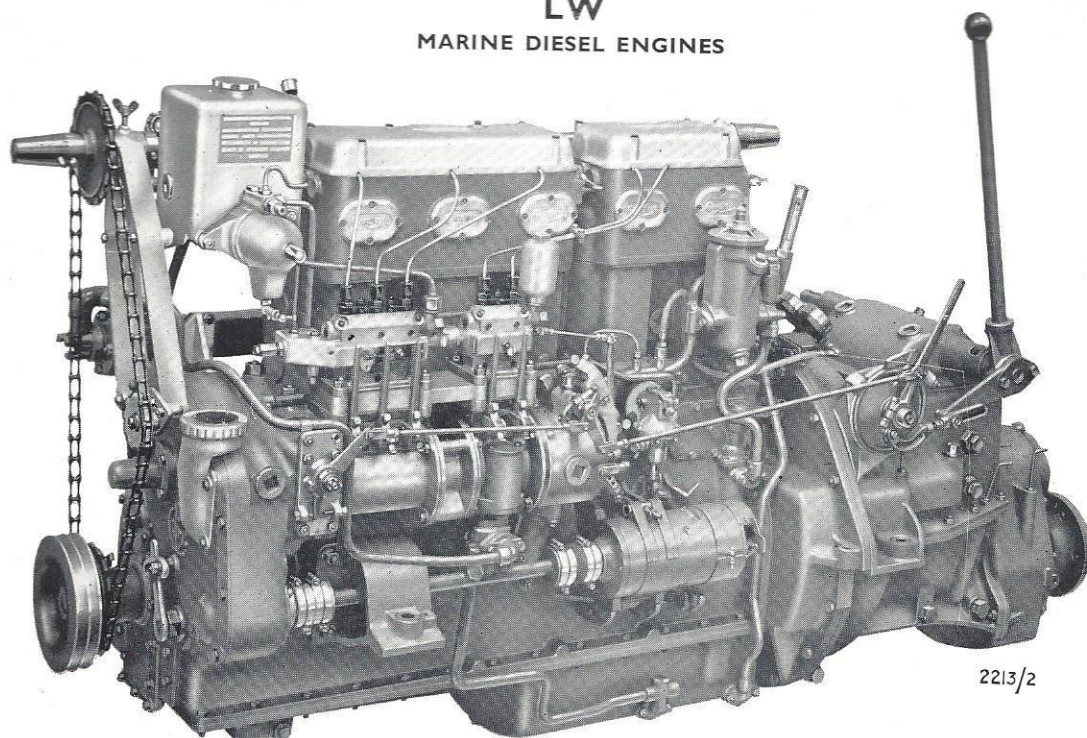

2213/2

5LW Engine with No. 2 U.C. Reversing and 2:1 Reducing Gears, showing above, the oil cooler pump mounted on the fuel pump cam box assembly and below, the oil cooler located alongside the cylinder blocks.

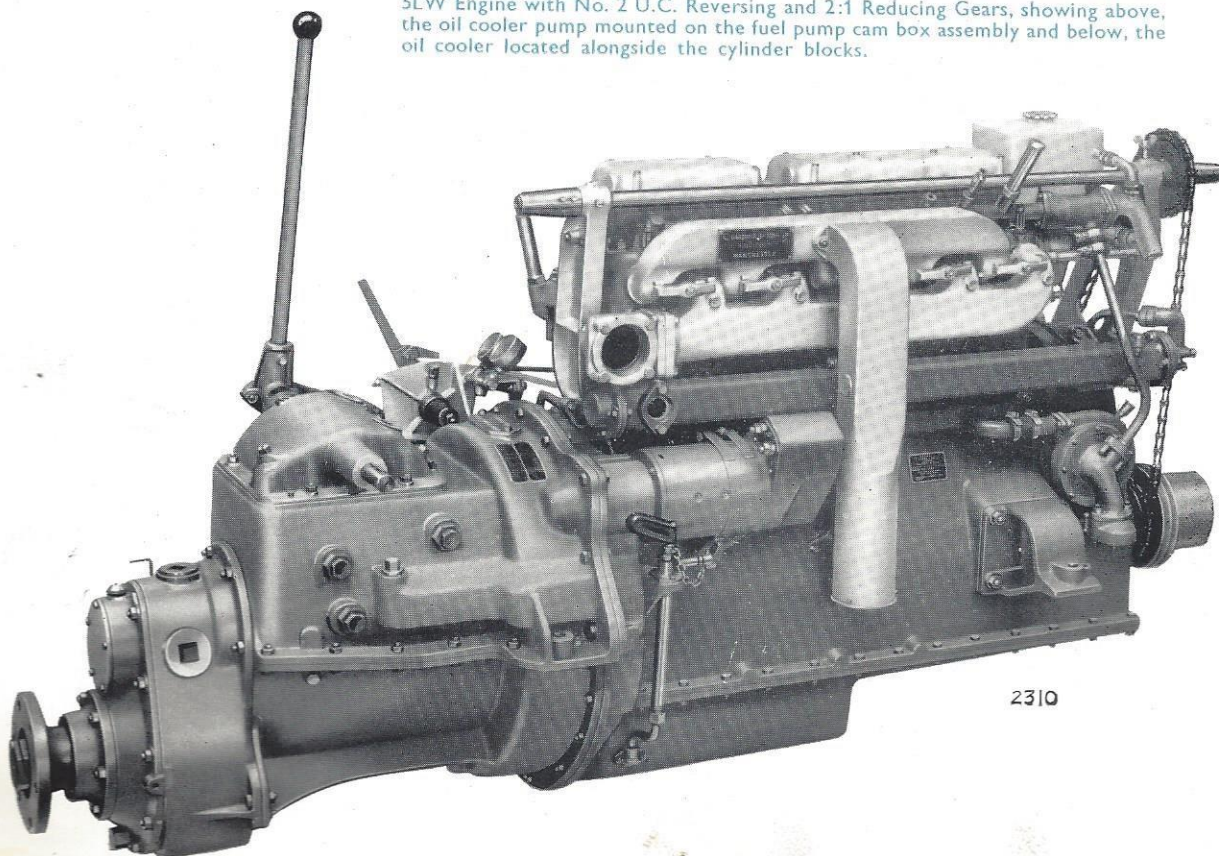

2310



GARDNER

LW

MARINE DIESEL ENGINES

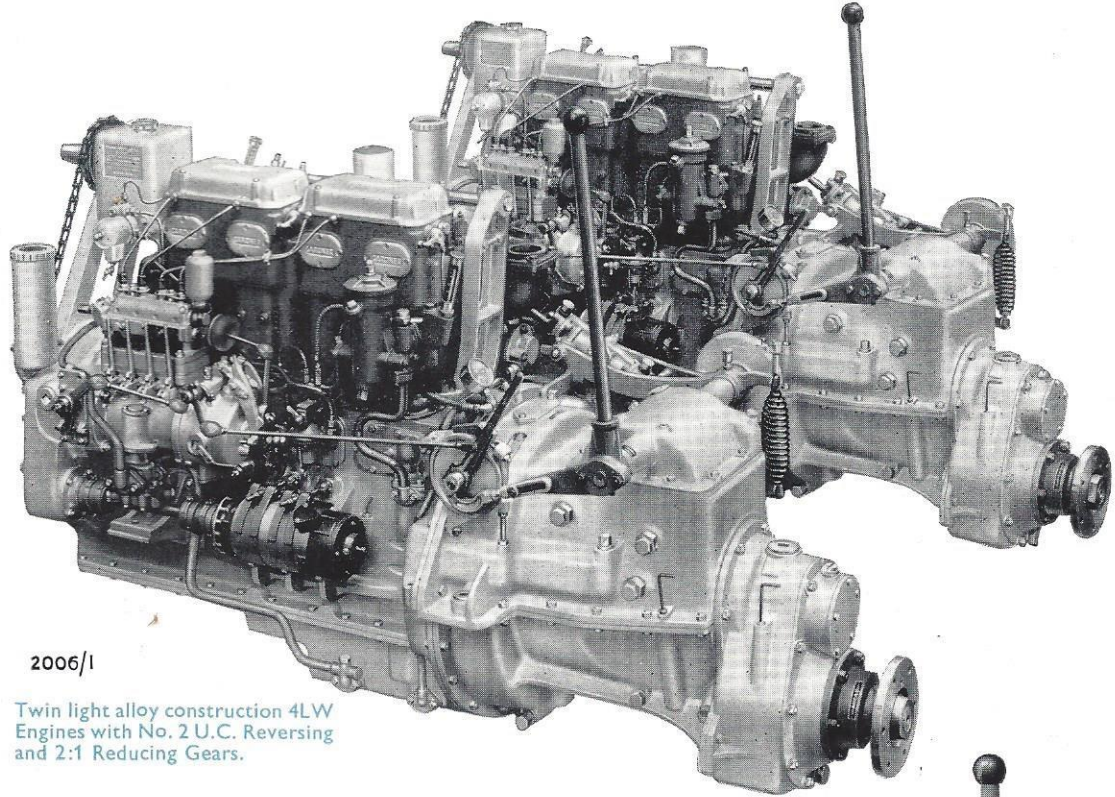

2006/1

Twin light alloy construction 4LW Engines with No. 2 U.C. Reversing and 2:1 Reducing Gears.

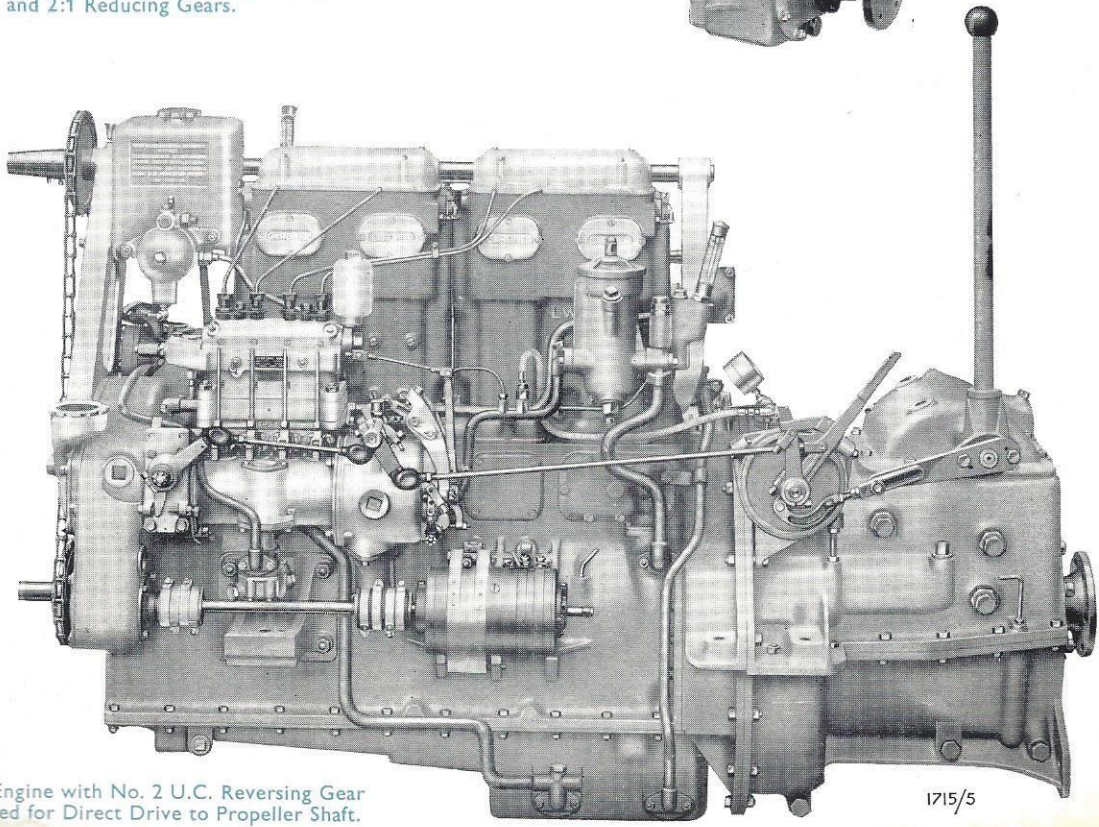

4LW Engine with No. 2 U.C. Reversing Gear arranged for Direct Drive to Propeller Shaft.

1715/5